



## Installation Instructions NT-IDS & NT-DUCT Net/X-Stat Remote Sensors

### Introduction

The NetworkThermostat remote sensors are designed to sense the air temperature at a remote location and send this information by digital communications to the thermostat. Up to six sensors can be connected together to provide temperature averaging. The sensors are supplied in surface mount cases, with an optional duct sensor probe. The electronics of the sensor can also be easily modified for connecting an existing 10K thermistor network to a Net/X-Stat thermostat.

### Single Sensor Installation

1. Install the Net/X-Stat thermostat according to the instruction manual supplied with it. Check that the thermostat is operating. Display shows the correct temperature. **CAUTION: Remove the thermostat from the sub-base while wiring the sensor to avoid damage from live wires. This is important.**
2. Install Category 5 UTP cable from the Net/X-Stat thermostat to the remote sensor location. Maximum distance is 300ft. (90m)
3. Open the sensor case by depressing the button on the bottom edge of the case until the latch releases. Remove the cover by pulling it out and up at the bottom.
4. Remove the board from the sub-base by pulling back the latch that holds it at the center bottom.
5. Use the sub-base as a template to mark the mounting hole locations on the wall. Drill size for the wall anchors is 1/4 inch. Mount the sub-base over the wires coming out of the wall using the two screws and anchors provided. The angled corner on the sub-base should be in the bottom right.
6. Snap the board back into the sub-base. Check to be sure that the latch holds the board properly. Check that the thermistor (sensor element) is positioned under the holes in the cover but not touching the cover or sub-base.
7. Strip 1/4 inch of insulation from three wires at the remote sensor. Install the wires in the terminals using the Table below. Push any extra wire back into the wall cavity. Seal the hole in the wall around the cable to eliminate any draft that might affect the sensor. (Refer to Figure 1.)
 

RS+V	= Green with White Stripe
RS2	= White with Green Stripe
RS1	= Brown with White Stripe
8. Note the wire color going to each terminal. The order of the wires on the thermostat is not the same as the sensor.
9. Connect the wires on the thermostat sub-base to the terminals labeled RS2, RS1 and RS+V. Make sure that each terminal on the sensor is wired to the terminal with the same name on the thermostat.
10. Mount the thermostat on the sub-base and check to be sure that it is showing the temperature.
11. Reinstall the cover on the remote sensor by hooking it on the top and snapping the bottom into place.

### Using Multiple Sensors for Temperature Averaging

Any number from two to six sensors may be connected together to provide temperature averaging in a large area or several zones being controlled by the same system. Maximum distance between any 2 sensors is 300 ft. (90m)

1. Wire the first sensor using the single sensor instructions.

2. **CAUTION: Make sure there is no power to the sensors by removing the thermostat from the sub-base.**
3. Connect wires to each additional sensor in the following manner. An outdoor sensor also can be connected in any location in the chain. (Refer to Figure 2.)

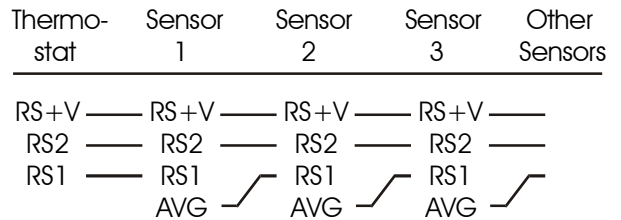

4. Replace the thermostat on the sub-base. Check for proper operation of each sensor by temporarily connecting a jumper between terminals 1 and 2. This shorts out the thermistor. The displayed temperature will go up several degrees if the sensor is properly installed. Once tested, remove the jumper. Repeat for each sensor.

### Retrofit to Multiple 10K Thermistors

If an older thermostat with multiple sensors is replaced, the existing 10K thermistor network may still be used. An NT-IDS sensor must be added between them and the new thermostat.

1. Install the new sensor using the single sensor instructions.
2. Clip the thermistor from the new sensor with wire cutters as shown in Figure 3.
3. Connect the two-wire cable from the 10K thermistor network to terminals 1 and 2 of the new sensor. If present, connect the shield of the cable to terminal 2 also.

### Using the NT-DUCT Sensor

The sensor and thermostat are designed to sense air temperature in a room. It is important that the NT-DUCT sensor is placed as close to the return air duct as possible. The fast moving air in a duct has small but rapid changes in temperature. This will affect the control algorithm of the thermostat if not mounted properly.

1. Install the indoor sensor using the single sensor instructions.
2. Clip the thermistor from the indoor sensor with wire cutters as shown in Figure 3.
3. Install the duct sensor in the return air duct according to the diagram in Figure 3. Connect the two wires from the duct sensor to terminals 1 and 2 of the indoor sensor. If shielded cable was required because of a long distance to the sensor box, connect the shield to terminal 2 also.

### Troubleshooting

**Thermostat has no display :** Check wiring between thermostat and sensor. Incorrect wiring can damage the thermostat, transformer or blow a fuse. Check the 24VAC supply.

**Thermostat reads AC :** 24VAC power is disconnected.

**Not sure if display is showing local or remote temperature :** Breathe on the wall near the bottom left corner of the thermostat. The temperature will go up for a few seconds if sensing locally

**Thermostat displays very high temperature :** Wires on the sensor element are shorted together. Separate them.

**Thermostat displays very low temperature :** Check wiring of the probe or duct sensor. The sensor element is not connected to board or is broken.

# NT-IDS & NT-DUCT INSTALLATION DIAGRAMS

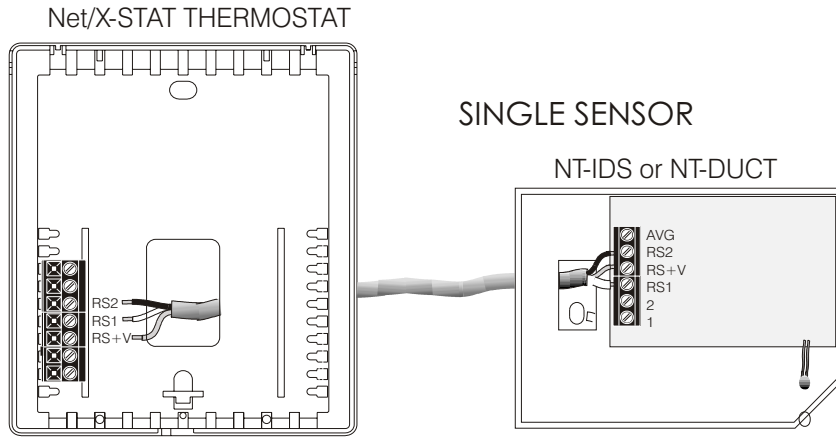

Specifications:  
 Power Supply : 12 to 30 VAC or DC (24V Nominal)  
 Operating Temperature : 0 to 50 Deg. C  
 Maximum Relative Humidity : 90 % (non-condensing)  
 Measurement Range : 0 to 48 Deg C ( 28 to 124 Deg F)  
 Accuracy : +/- 1 Deg C from 15 to 30 Deg C  
 (+/- 2 Deg F at 68 Deg F)  
 after 30 minutes of continuous operation  
 Max Cable Length Between 2 Units: 300 Ft, with CAT 5 UTP  
 Cable Type : CAT 5 UTP  
 Max Number of Indoor Sensors in a Daisy Chain: 6  
 Max Number of Outdoor Sensors in a Daisy Chain: 1

Indoor Sensors Automatically Calculate the Average Across All Connected Indoor (and Duct) Sensors

Figure 1

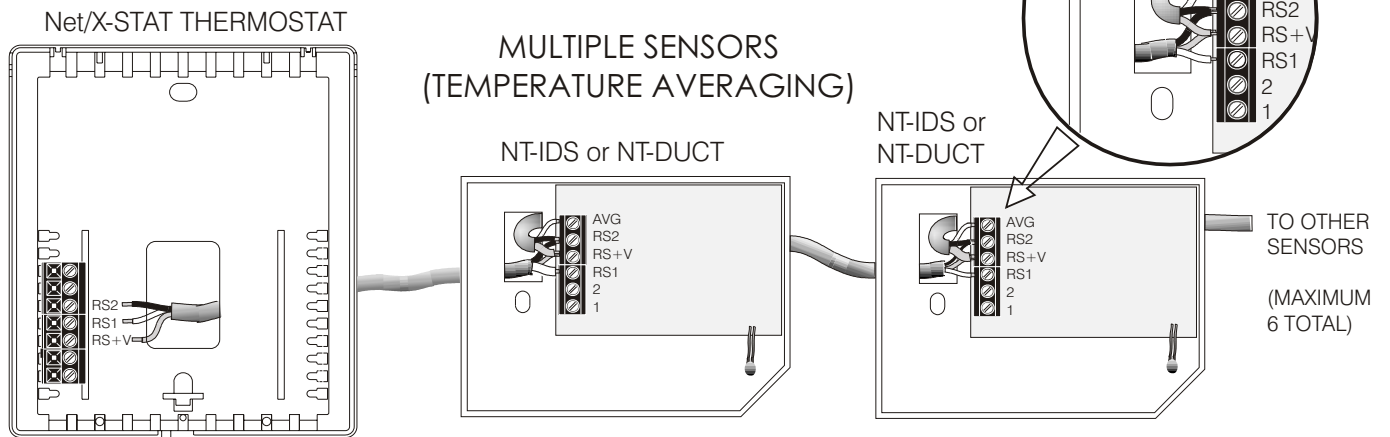

Figure 2

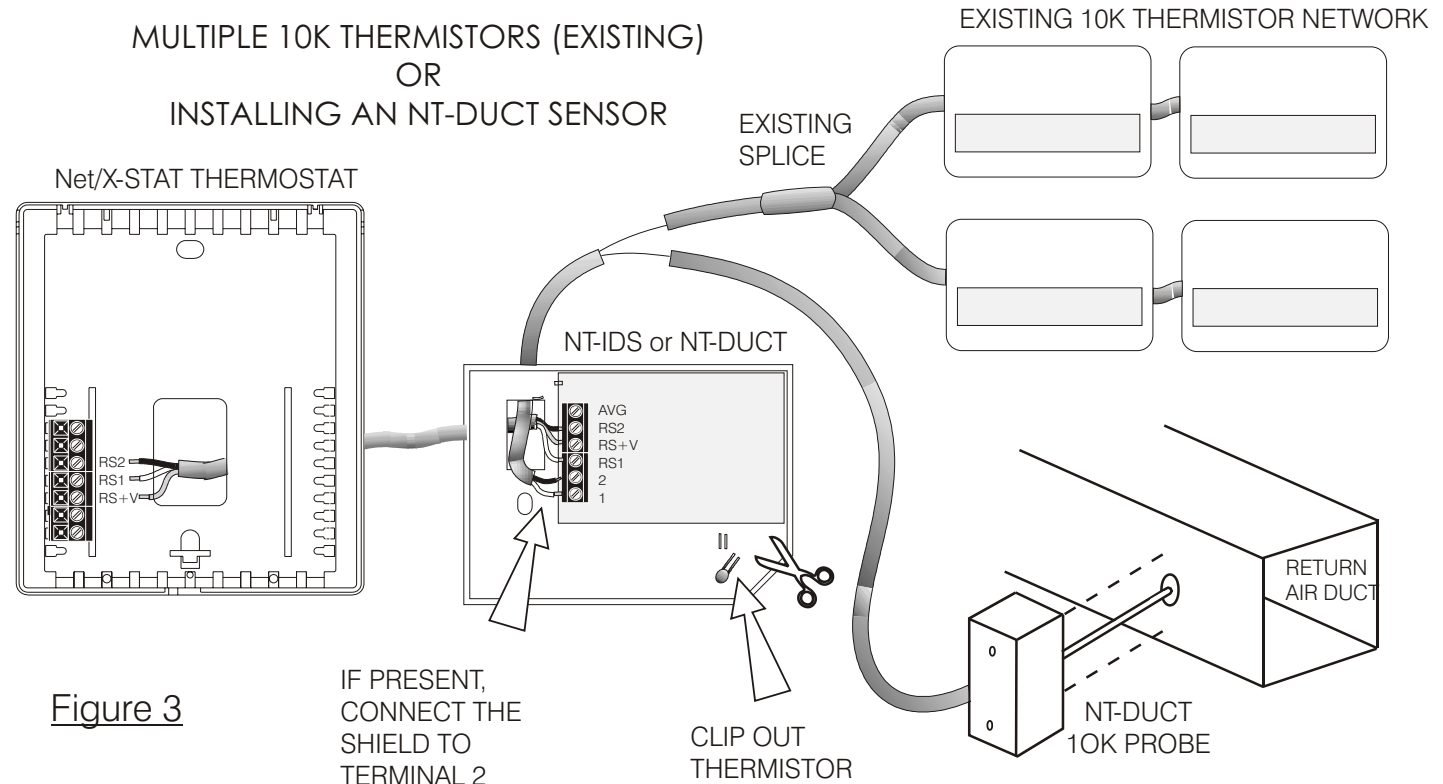

Figure 3