



X5H-IP

- **Commercial Grade Ethernet Thermostat**
- **Standard (Gas/Electric) up to 2H/2C**
- **Heat Pump up to 3H/2C**
- **Advanced Remote Sensor Bus**
- **Full Color Touchscreen**
- **7 Day Programmable ~ 4 Events/Day**
- **80 Additional Event Schedules**
- **Onboard Data Logging**
- **Humidity Control**

GENERAL DESCRIPTION:

Complete Stand-Alone Solution

The X5H-IP is an Ethernet color touchscreen thermostat with an advanced remote sensor bus, designed for new or replacement commercial or residential applications. Our integrated logic for both conventional and heat pump applications can be configured for up to three (3) stages of heating and two (2) stages of cooling. DirectConnect™ helps deliver a near-effortless setup of your daily schedules (4 events per day) and up to 80 Additional Events (40 Special and 40 Calendar Events). The unique scheduling structure also supports the powerful features of adjustable temporary override times and temperature ranges, occupied and unoccupied events, keypad lockout, and many more features.

The X5H-IP is designed to operate with our CloudConnect™ Online Management software or, for maximum security, behind your firewall using DirectConnect™ or our PCConnect™ Software. Since all HVAC functions are stored in the thermostat, the X5H-IP will continue to operate even during network outages, allowing you to maintain your energy savings. For ultimate control over energy usage, the X5 offers a digital lockout that can permit limited temperature overrides based on your requirements. Our on-board data collection allows for historical review, sub-metering, and run-time reporting.

STANDARD FEATURES:

CloudConnect™ & CloudManager™ Available

Energy Savings

- Efficient Equipment Restart™ randomizes equipment starts to minimize multiple units turning on simultaneously when there are multiple NetX thermostats at the location
- Random Restart on power up staggers restart of HVAC system after a power outage to minimize peak in-rush current
- Adaptive Recovery for Schedules allows system to achieve desired setpoint at the beginning of the schedule

Monitoring

- 11 Remote Sensors: up to 6 indoor, 1 humidity, 1 outdoor, and up to 3 auxiliary sensors for monitoring items such as supply air, return air, walk-in refrigerators and freezers, etc.
- 2 Digital Inputs for Fault Conditions, including Condensate and Equipment Faults
- Occupancy Sensor Input
- On-board Data Logging with Sub-Metering Support

Connectivity

- CloudConnect™ Internet-Based Cloud Service
- PCConnect™ Software Local Network & Port Forwarded Access
- DirectConnect™ Integrated Web Server for Connectivity from Any Modern Web Browser
- Integrated NetX™ API, Supports 3rd Party Apps
- BACnet Integration Option

Facility Management

- 4 independent schedules per day
- 80 Additional Event Schedules (40 Special and 40 Calendar Events)
- Commercial Lockout with Programmable Temporary Override Time and Temp Adjustment
- Email & Text Message Alerting for 4 Locations
- Alerts include Hi/Lo Temps for Indoor, Outdoor, Supply, Return, and Aux Temps, Inefficient Equipment Runs, Change Filter Notifications, and Two Digital Inputs: 19 Alerts in All

General

- Color Selectable Touchscreen Display, Black or White Case
- Modes: Heat, Cool, Automatic Changeover, and Off
- Integrated Humidity Sensor & Humidification and Dehumidification Control
- Fan Selector for Automatic or Continuous Fan Operation; Programmable Recirculation Fan
- Integrated Weather with Current Conditions and 7-Day Forecasts



SPECIFICATIONS:

Rated Voltage:	20V to 30VAC, 24VAC nominal
Rated A.C. / D.C. Current:	0.05 to 0.75 AC / 0.0 to 0.75 DC Amp continuous, per output, surges to 3 Amps maximum
Temperature Control Range:	Heating: 38°F to 88°F (4°C to 31°C) in 1° steps Cooling: 60°F to 108°F (16°C to 42°C) in 1° steps
Thermostat Sensing Range:	32°F to 118°F (0°C to 48°C) Control Accuracy: ±1°F @ 68°F (±0.5°C @ 20°C)
Minimum Deadband:	2°F (1°C)
Humidity Control Range:	Humidify: 10% to 60%RH in 5%RH steps Dehumidify: 35% to 75%RH in 5%RH steps
Dimensions:	5.1"H x 4.7"W x 1.15"D (130mm x 119mm x 29mm)
Equipment Terminations:	R - 24V switching voltage, W1 - Heat1 or Aux/Emer Heat, G - Fan, Y1-Compressor1, Y2 - Compressor2, O/W2 - Heat2 or Rev. Valve in Cooling, B - Rev. Valve in Heating
Power Terminations:	24V - remote power (not used), 24V(c) - power common (from HVAC equipment)
Input Terminations:	LED1 (Filter Icon Selectable), LED2 (Fault Icon Selectable)
Occupancy Terminations:	CLK1 (+), CLK2 (-)
Remote Sensor Terminations:	RS+V - Power, RS2 - Return, RS1 - Data
Communication Terminations:	X1 - XBus (+), X2 - XBus (-)

WIRING DIAGRAMS:

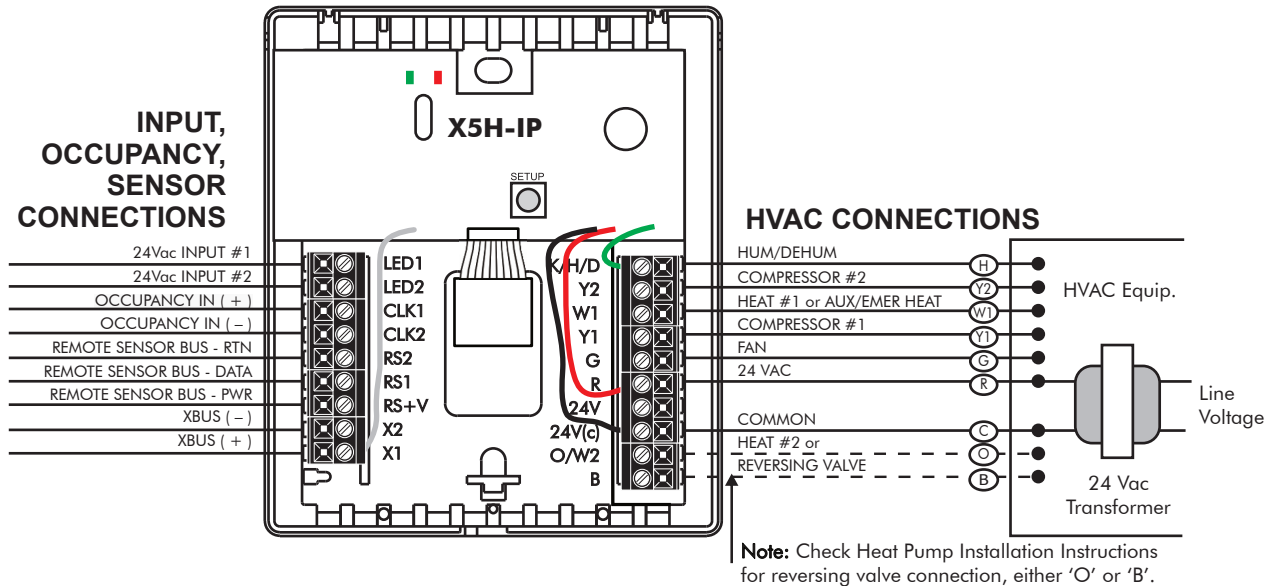

OUTPUT TERMINAL FUNCTIONS

LED1 24Vac Input #1 for Filter or other Alert	K/H/D Humidification or Dehumidification or Aux. Relay 1
LED2 24Vac Input #2 for Condensate, Fault or other Alert	Y2 Energizes compressor for second stage cooling, or for heat pumps, either second stage heating or cooling
CLK1 For use with External Occupancy Sensor (+)	W1 Energizes heater for first stage heating, or for heat pumps, aux/emmer heat
CLK2 For use with External Occupancy Sensor (-)	Y1 Energizes compressor for first stage cooling, or for heat pumps, either first stage heating or cooling
RS2 Remote Sensor Bus (Power Return)	G Energizes fan circuit with a call for heating or cooling
RS1 Remote Sensor Bus (Data)	R Independent Switching Voltage from HVAC equip
RS+V Remote Sensor Bus (Power)	24V 24Vac
X2 Communications bus (-)	24V(c) 24Vac Common
X1 Communications bus (+)	O/W2 Energizes heater for second stage heating, or for heat pumps, energizes the reversing valve in cooling mode
	B Energizes the reversing valve in heating mode